

# Anti-Cavitation Hytrol Valve

- **Virtually Cavitation Free Operation**
- **Severe Service Design - High Pressure Differentials**
- **Reduced Noise and Vibration**
- **316 Stainless Steel Trim Standard**
- **Service Without Removal From Line**
- **Drip -Tight, Positive Sealing**
- **Retrofit to Standard Hytrol Valves**

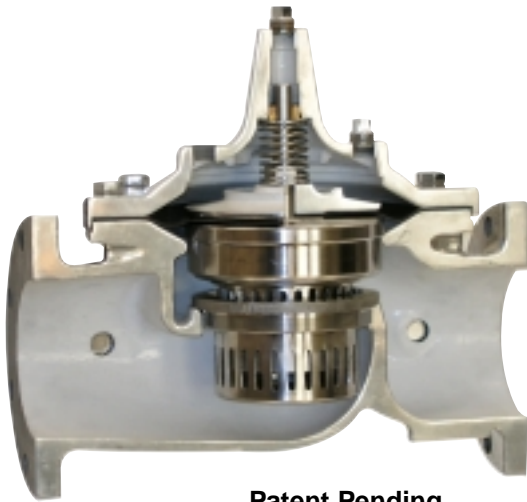

**Patent Pending**

The Cla-Val Model 100-01KO Anti-Cavitation Hytrol Valve is designed for applications where there is a high potential for damage from cavitation. Specify this valve series for a wide variety of control valve applications having pressure differentials up to 300 PSID or for relief valves having atmospheric discharge up to 150 PSID.

The 100-01KO Hytrol main valve provides optimum internal pressure control through a unique anti-cavitation trim (patent-pending) design. Constructed of 316 Stainless Steel, the seat and disc guide trim components feature dual interlocked sleeves containing radial slots that deflect internal flow to impinge upon itself in the center of the flow path, harmlessly dissipating the potential cavitation damage. This unique design also lessens the possibility of fouling if large particles in the water are present due to the large flow path of the radial slots.

The 100-01KO Hytrol is the basic valve used in Cla-Val Automatic Control Valves for high differential applications requiring remote control, pressure regulation, solenoid operation, rate of flow control, or liquid level control.

The Anti-Cavitation Trim components can be retrofitted to existing valves if the application indicates an appropriate need. Please consult factory for details.

## Principle of Operation

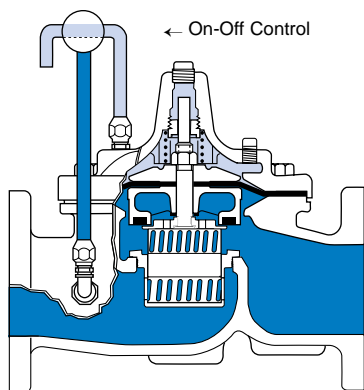

**Full Open Operation**

When pressure in the cover chamber is relieved to a zone of lower pressure, the line pressure at the valve inlet opens the valve, allowing full flow.

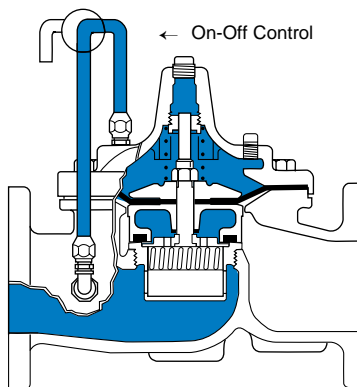

**Tight Closing Operation**

When pressure from the valve inlet is applied to the cover chamber, the valve closes drip-tight.

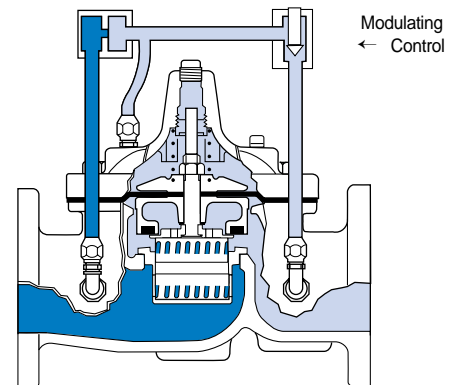

**Modulating Action**

The valve holds any intermediate position when operating pressures are equal above and below the diaphragm. A Cla-Val "Modulating" Pilot Control will allow the valve to automatically compensate for line pressure changes.

## Specifications

Model 100-01KO

### Available Sizes

Pattern	Flanged
Globe	3" - 16"
Angle	Consult Factory

### Operating Temp. Range

Fluids
-40° to 180° F

Component	Material Options				
Body & Cover	Ductile Iron	Cast Steel	Bronze	Stainless Steel	Aluminum
Available Sizes	3" - 16"	3" - 16"	3" - 16"	3" - 16"	3" - 16"
Disc Retainer & Diaphragm Washer	Ductile Iron	Cast Steel	Bronze	Stainless Steel	Aluminum
Trim: Disc Guide, Seat & Cover Bearing	316 Stainless Steel is Standard				
Disc	Buna-N® Rubber				
Diaphragm	Nylon Reinforced Buna-N® Rubber				
Stem, Nut & Spring	Stainless Steel				

### Pressure Ratings (Recommended Maximum Pressure - psi)

Valve Body & Cover		Pressure Class			
		Flanged			Screwed
Grade	Material	ANSI Standards*	150 lb.	300 lb.	End** Details
ASTM A536	Ductile Iron	B16.42	250	400	400
ASTM A216-WCB	Cast Steel	B16.5	285	400	400
ASTM B62	Bronze	B16.24	225	400	400
ASTM A743	Stainless Steel	B16.5	285	400	400
356-T6	Aluminum	B16.1	275	—	—

Note: \*ANSI standards are for flange dimensions only.  
Flanged valves are available faced but not drilled.  
\*\*End Details machined to ANSI B2.1 specifications.

100-01KO (Globe)

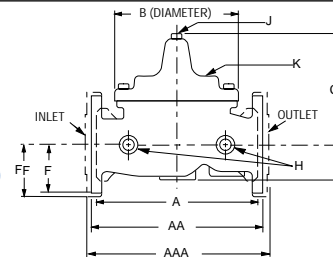

## Dimensions

Valve Size (Inches)	3	4	6	8	10	12	16	(mm)	80	100	150	200	250	300	400
A Screwed	12.50	—	—	—	—	—	—	A	318	—	—	—	—	—	—
AA 150 ANSI	12.00	15.00	20.00	25.38	29.75	34.00	41.38	AA	305	381	508	645	756	864	1051
AAA 300 ANSI	13.25	15.62	21.00	26.38	31.12	35.50	43.50	AAA	337	397	533	670	790	902	1105
B Dia.	9.12	11.50	15.75	20.00	23.62	28.00	35.50	B	232	292	400	508	600	711	902
C Max.	8.19	10.62	13.38	16.00	17.12	20.88	25.00	C	208	270	340	406	435	530	635
E	2.56	3.19	4.31	5.31	9.25	10.75	15.50	E	65	81	267	135	235	273	394
F 150 ANSI	3.75	4.50	5.50	6.75	8.00	9.50	11.75	F	95	114	110	171	203	241	298
FF 300 ANSI	4.13	5.00	6.25	7.50	8.75	10.25	12.75	FF	105	127	140	191	222	260	324
H NPT Body Tapping	1/2	3/4	3/4	1	1	1	1	H	1/2	3/4	3/4	1	1	1	1
J NPT Cover Center Plug	1/2	3/4	3/4	1	1	1 1/4	2	J	1/2	3/4	3/4	1	1	1 1/4	2
K NPT Cover Tapping	1/2	3/4	3/4	1	1	1	1	K	1/2	3/4	3/4	1	1	1	1
Valve Stem Internal Thread UNF	1/4-28	1/4-28	3/8-24	3/8-24	3/8-24	3/8-24	1/2-20	Internal Thread	1/4-28	1/4-28	3/8-24	3/8-24	3/8-24	3/8-24	1/2-20
Stem Travel	0.8	1.1	1.7	2.3	2.8	3.4	4.5	Stem Trvl	20	28	43	58	71	86	114
Approx. Ship Wt. Lbs.	70	140	285	500	780	1165	2265	Wt. Kgs.	32	64	129	227	354	528	1027

Cla-Val Control Valves with KO ANTI-CAVITATION Trim operate with maximum efficiency when mounted in horizontal piping with the main valve cover up. We recommend isolation valves be installed on inlet and outlet for maintenance. Adequate space above and around the valve for service personnel should be considered essential. A regular maintenance program should be established based on the specific application data. However, we recommend a thorough inspection be done at least once a year. Consult factory for specific recommendations.

## Functional Data

Valve Size		Inches	3	4	6	8	10	12	16
		mm.	80	100	150	200	250	300	400
C <sub>v</sub> Factor	Globe Pattern	Gal./Min. (gpm.)	52	90	218	362	469	810	1382
		Litres/Sec. (l/s.)	12.5	22	52	87	113	195	332
Equivalent Length of Pipe	Globe Pattern	Feet (ft.)	416	572	858	1315	2444	2118	2279
		Meters (m.)	127	174	261	401	745	646	695
K Factor	Globe Pattern		29.3	29.0	25.5	27.9	41.0	27.7	23.7
Liquid Displaced from Diaphragm Chamber When Valve Opens	Fl. Oz		—	—	—	—	—	—	—
	U.S. Gal.		—	.17	.53	1.26	2.51	4.0	9.6
	ml		—	643	—	—	—	—	—
	Litres		—	—	2.0	4.8	9.5	15.1	36.2

For assistance in selecting appropriate valve options or valves manufactured with special design requirements, please contact our Regional Sales Office or Factory.

Patent Pending

**C<sub>V</sub> Factor**

Formulas for computing C<sub>V</sub> Factor, Flow (Q) and Pressure Drop (ΔP):

$$C_V = \frac{Q}{\sqrt{\Delta P}} \quad Q = C_V \sqrt{\Delta P} \quad \Delta P = \left(\frac{Q}{C_V}\right)^2$$

**K Factor (Resistance Coefficient)**

The Value of K is calculated from the formula:  $K = \frac{894d^4}{C_V^2}$   
(U.S. system units)

**Equivalent Length of Pipe**

Equivalent lengths of pipe (L) are determined from the formula:  $L = \frac{Kd}{12f}$   
(U.S. system units)

**Fluid Velocity**

Fluid velocity can be calculated from the following formula:  $V = \frac{.4085 Q}{d^2}$   
(U.S. system units)

**Where:**

**C<sub>V</sub>** = U.S. (gpm) @ 1 psi differential at 60° F water  
or

= (l/s) @ 1 bar (14.5 PSIG) differential  
at 15° C water

**d** = inside pipe diameter of Schedule 40 Steel Pipe (inches)

**f** = friction factor for clean, new Schedule 40 pipe  
(dimensionless) (from Cameron Hydraulic Data,  
18th Edition, P 3-119)

**K** = Resistance Coefficient (calculated)

**L** = Equivalent Length of Pipe (feet)

**Q** = Flow Rate in U.S. (gpm) or (l/s)

**V** = Fluid Velocity (feet per second) or (meters per second)

**ΔP** = Pressure Drop in (psi) or (bar)

**100G-01KO ANTI-CAVITATION VALVE CURVES**

SOLID LINE IS FULL OPEN FLOW CURVES FOR 18 FT/SEC CONTINUOUS DUTY APPLICATIONS  
DASHED LINE IS FULL OPEN FLOW CURVE FOR 25 FT/SEC INTERMITTENT DUTY APPLICATIONS

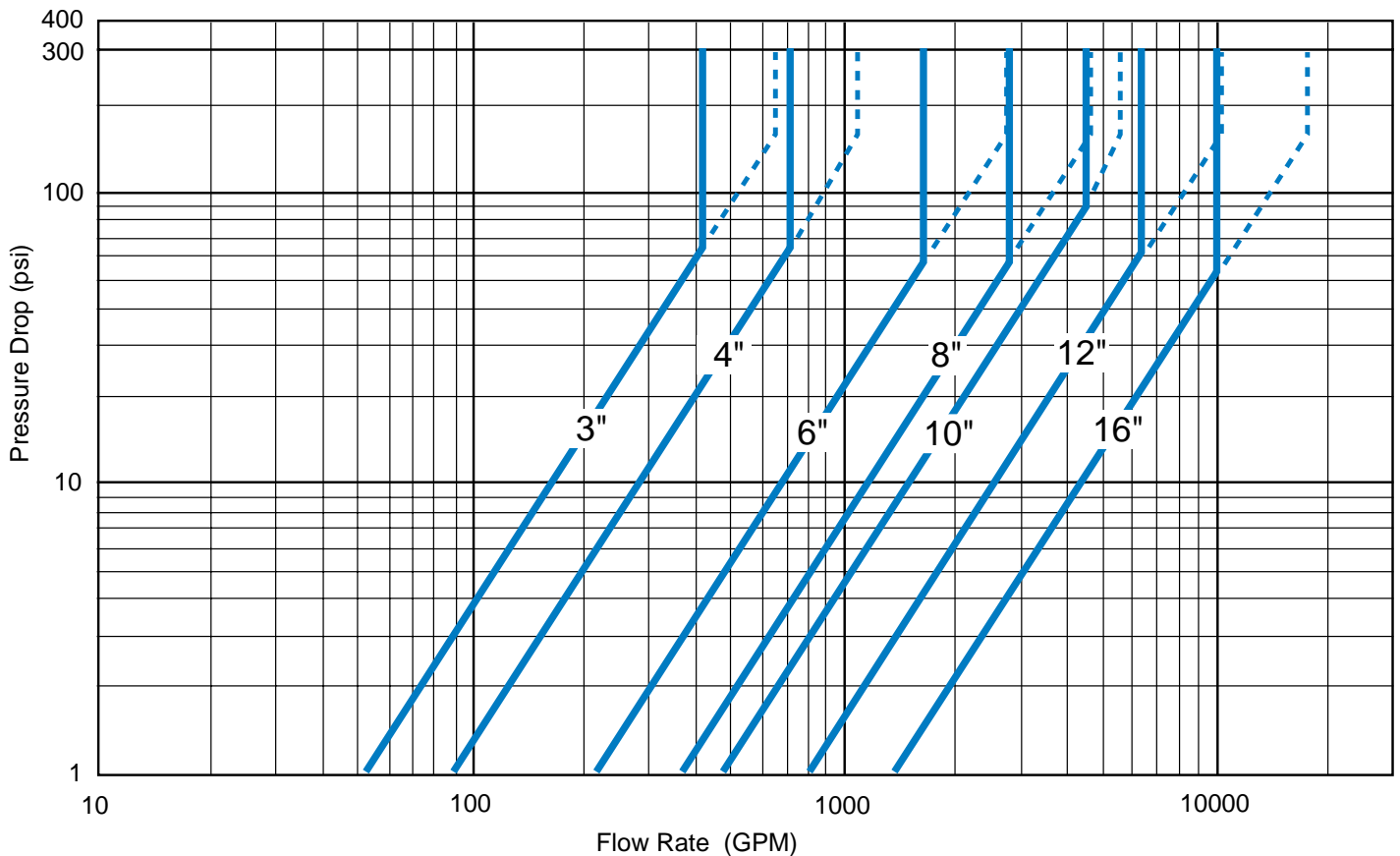

**Notes: on operating differential**

1. For atmospheric discharge, the maximum inlet pressure cannot exceed 150 PSI.
2. Above 150 PSI inlet pressure, a minimum of 25 PSI outlet pressure is required.
3. Maximum pressure differential cannot exceed 300 PSID.
4. Recommended Minimum flow is 1 foot per second velocity flow capacity.
5. Consult factory for conditions exceeding these recommendations.

### Function

The valve shall be hydraulically operated, single diaphragm actuated, globe pattern. The valve shall consist of three major components: the body with seat installed, the cover with bearing installed, and the diaphragm assembly. The diaphragm assembly shall be the only moving part and shall form a sealed chamber in the upper portion of the valve, separating operating pressure from line pressure. Packing glands and/or stuffing boxes are not permitted and there shall be no pistons operating the main valve or pilot controls. Valve body and cover shall be of cast material manufactured in North America. Ductile Iron is standard, other materials shall be available. No fabrication or welding shall be used in the manufacturing process.

### Description

The anti-cavitation features of the seat and disc guide detail shall have flow slots equally spaced around their perimeters. The seat slots shall be orientated around the perimeter of the seat so that fluid entering the valve shall flow through the seat slot detail such that the fluid flow converges in the center chamber of the seat allowing potential cavitation to dissipate. The disc guide slots shall be positioned around the perimeter of the disc guide, configured and oriented in an angular direction so that fluid flow exiting through the slots is diverted away from direct impact into pressure boundary surfaces. Flow exiting the disc guide slots is directed in an angular path to increase the distance between the slot geometry and pressure boundary surfaces. If cavitation conditions exist, the increased distance between the slots and pressure boundary surfaces minimizes the potential for damage by allowing the cavitation bubbles to dissipate before they come in contact with pressure boundary surfaces. Anti-cavitation characteristics shall be controlled by the described slotted seat and disc guide components. The disc guide shall slide in the seat and allow controlled flow through the seat slots into the central seat chamber where flow shall continue from the seat chamber and exit through the angularly oriented slots of the disc guide. The seat and disc guide features used together shall provide anti-cavitation characteristics suitable for applications where a large controlled pressure drop is desired.

The flexible, non-wicking, FDA approved diaphragm shall consist of nylon fabric bonded with synthetic rubber compatible with the operating fluid. The diaphragm must withstand a Mullins burst test of a minimum of 600 psi per layer of nylon fabric and shall be cycle tested 100,000 times to insure longevity. The diaphragm shall be fully supported in the valve body and cover by machined surfaces which support no less than one-half of the total surface area of the diaphragm in either the fully open or fully closed position.

The valve seat in six inch and smaller size valves shall be threaded into the body. Valve seat in eight inch and larger size valves shall be retained by flat head machine screws for ease of maintenance. The seat shall be of the solid, one piece design and shall have a minimum of a five degree taper on the seating surface for positive drip tight shut-off. Pressed-in bearings and/or multi-piece seats shall not be permitted.

To insure proper alignment of the valve stem, the valve body and cover shall be machined with a locating lip. No "pinned" covers to the valve body shall be permitted. All necessary repairs and/or modifications other than replacement of the main valve body shall be possible without removing the valve from the pipeline.

The valve manufacturer shall warrant the valve to be free of defects in material and workmanship for a period of three years from date of shipment, provided the valve is installed and used in accordance with all applicable instructions. The valve manufacturer shall be able to supply a complete line of equipment from 1 1/4" through 24" sizes and a complete selection of complementary equipment.

### Material Specification

Valve Size:	Pressure Rating:
Main Valve Body and Cover:	Temperature Range:
Main Valve Trim:	Coating:
End Detail:	Desired Options:

### Application Information

Inlet/Outlet Pressures:  
Flow Rate:  
Pipe Diameter:  
Function (i.e. - Pressure Reducing, Pressure Relief, etc.):

This valve shall be a Cla-Val Model No. 100-01KO Hytrol Main Valve with Anti-Cavitation Trim as manufactured by Cla-Val, Newport Beach, CA

**Note:** Add this Hytrol Anti-Cavitation Trim Purchase Specification to main valve specification for control valves where there is a high potential for cavitation damage. Please contact our Regional Sales Offices or Factory for assistance.

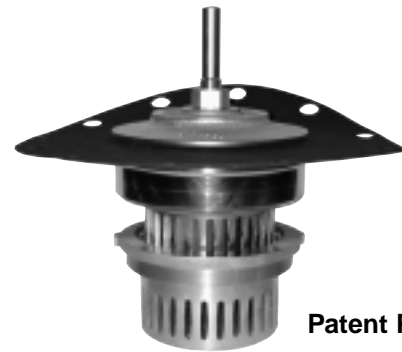

Patent Pending

The Anti-Cavitation Trim components can be retrofitted to existing Hytrol valves if the application indicates an appropriate need. Please consult factory for details.



### CLA-VAL

PO Box 1325 Newport Beach CA 92659-0325  
Phone: 949-722-4800 • Fax: 949-548-5441

#### CLA-VAL CANADA

4687 Christie Drive  
Beamsville, Ontario  
Canada LOR 1B4  
Phone: 905-563-4963  
Fax: 905-563-4040

#### CLA-VAL EUROPE

Chemin des Mésanges 1  
CH-1032 Romanel/  
Lausanne, Switzerland  
Phone: 41-21-643-15-55  
Fax: 41-21-643-15-50

COPYRIGHT CLA-VAL 2003 Printed in USA  
Specifications subject to change without notice.

[www.cla-val.com](http://www.cla-val.com)

Represented By: