



— MODEL — **X140**

Locking Security Cap



- **Controlled Security for Pilot Control Adjustment**
- **Long Life Stainless Steel Construction**
- **Tamper-Resistant Design**
- **Simple Maintenance**

The Cla-Val Model X140 Locking Security Cap is designed to completely encapsulate the pilot control adjustment screw with Stainless Steel. Even in the harshest environment, the X140 offers an extra level of protection, security and peace of mind for the system operator that pilot control settings will not change until appropriate personnel are present.

The X140 Locking Security Cap is available in two sizes for attaching to all Cla-Val pilot controls in place of the standard plastic cap. With lever in install position, the X140 is easily installed by hand onto pilot control. After installing the X140 Cap, simply move lever to lock position and install customer-supplied padlock in security hole. This allows protective cover to rotate freely without removal from pilot control.

When pilot control adjustment is needed, remove padlock and move lever, turn until pin self-locates and unscrew X140 Cap from pilot control. The once-a-year maintenance step is putting a small amount of synthetic lubricating grease in supplied Zirk fitting.

Dimensions (In Inches)

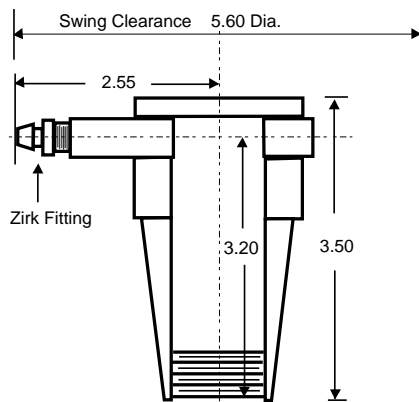
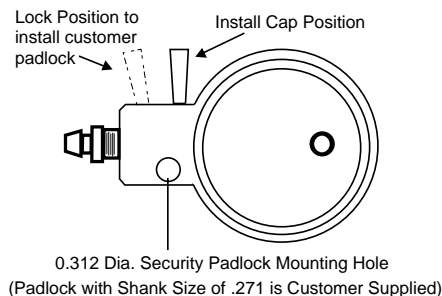

Small Cap Controls have 13/16 - 20 THD. use P/N# 20440701G

Large Cap Controls have 1 - 14 THD. use P/N# 20440702F



Specify on order complete pilot-control nameplate data to ensure proper fit of X140 to pilot control.