



— MODEL — 100-34 Hytrol Valve

- **Accurate Repeatable High Level Shut-off**
- **"Fail-Safe" Construction**
- **No Packing Glands Assure Leak-Proof Service**



The Cla-Val Model 100-34 Hytrol Valve is used as the basic unit in almost all Cla-Val automatic control valves for petroleum applications. The 100-34 is a hydraulically-operated, diaphragm actuated, globe or angle pattern valve. It is available in various materials and full range of sizes. It consists of three major components: body, diaphragm assembly and cover. The diaphragm assembly is the only moving part. The rugged simplicity of design and packless construction assure a long life of dependable, trouble-free operation. Should the diaphragm become damaged the valve will close tight, providing "fail safe" operation. The 100-34 Hytrol Valve is used in many types of piping system requiring remote control, pressure regulation, solenoid operation, rate of flow control, liquid level control, or check valve operation.

Principle of Operation

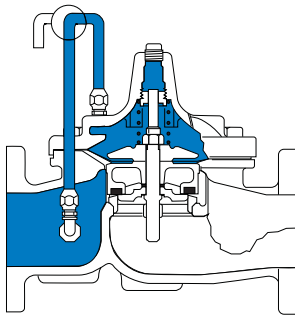

Tight Closing Operation

When pressure from the valve inlet (or an equivalent independent operating pressure) is applied to the diaphragm chamber, the valve closes drip-tight.

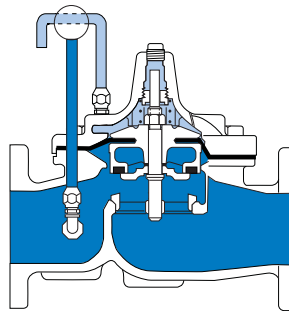

Full Open Operation

When pressure in the diaphragm chamber is relieved to zone of lower pressure under the valve. Flow in either direction is permitted.

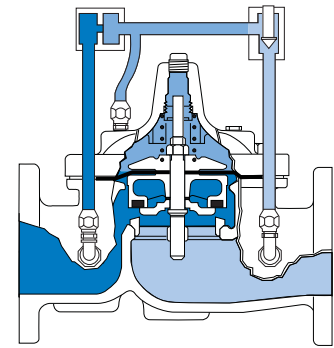

Modulating Action

The main valve modulates when diaphragm chamber pressure is held at an intermediate point between inlet and discharge pressure changes. Pressure above the diaphragm is varied, allowing the valve to modulate and compensate for the changes.

Specifications

Pressure Ratings (Recommended Maximum Pressure - psi)

Valve Body & Cover		Pressure Class				
		Flanged			Grooved	Threaded
Grade	Material	ANSI Standards*	150 Class	300 Class	300 Class	End‡ Details
ASTM A536	Ductile Iron	B16.42	250	400	400	400
ASTM A216-WCB	Cast Steel	B16.5	285	400	400	400
ASTM B62	Bronze	B16.24	225	400	400	400
356-T6	Aluminum	B16.3	275	---	---	---

Sizes: *Globe:* 1 1/2" - 16" flanged
Angle: 2" - 16" flanged

Valve trim:

Bronze ASTM B61
Cast Stainless Steel 300 Series

Rubber parts:

Buna-N® Synthetic Rubber
Viton

Other Materials

Available on Special Order

Note: * ANSI standards are for flange dimensions only. Flanged valves are available faced but not drilled.

‡ End Details machined to ANSI B2.1 specifications. • **Valves for higher pressure are available; consult factory for details**

SIZE	1 1/2	2	2 1/2	3	4	6	8	10	12	14	16
A 125 & 150 ANSI	8.50	9.38	11.00	12.00	15.00	20.00	25.38	29.75	34.00	39.00	41.38
AA 250 & 300 ANSI	9.00	10.00	11.62	13.25	15.62	21.00	26.38	31.12	35.50	40.50	43.50
B DIAMETER	5.62	6.62	8.00	9.12	11.50	15.75	20.00	23.62	28.00	32.75	35.50
C MAX.	5.50	6.50	7.56	8.19	10.62	13.38	16.00	17.12	20.88	24.19	25.00
D	1.12	1.50	1.69	2.06	3.19	4.31	5.31	9.25	10.75	12.62	15.50
E 125 & 150 ANSI	4.75	5.00	6.00	6.00	7.50	10.00	12.75	14.88	17.00	19.50	20.81
EE 250 & 150 ANSI	5.00	5.88	6.38	7.88	10.50	13.25	15.56	17.75	20.25	21.62	
F 125 & 150 ANSI	3.25	4.00	4.00	5.00	6.00	8.00	8.62	13.75	14.88	15.69	
FF 250 & 300 ANSI	3.50	4.31	4.38	5.31	6.50	8.50	9.31	14.50	15.62	16.50	

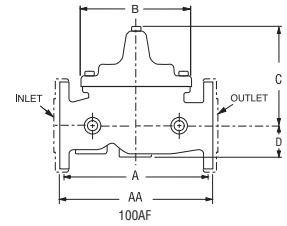

C_v Factor

VALVE SIZE	1 1/2	2	2 1/2	3	4	6	8	10	12
100-34 GLOBE PATTERN	26	49	80	107	200	440	771	1151	1600
100-34 ANGLE PATTERN	30	62	100	137					

C_v factor is defined as the number of gallons per minute of water at 60°F that will flow with a 1 psi pressure differential across the valve.

Purchase Specifications

The valve shall be hydraulically-operated, diaphragm-actuated, globe or angle pattern valve. It shall contain a resilient, synthetic rubber disc, having a rectangular cross section, contained on three and on-half sides by a disc retainer and disc guide, forming a tight seal against a single renewable seat. The valve stem shall be guided at both ends by a bearing in the valve cover and an integral bearing in the valve seat. The diaphragm assembly shall be the only moving part and shall form a sealed chamber in the upper portion of the valve, separating operating pressure from line pressure. The diaphragm consist of nylon fabric

bonded with synthetic rubber and shall not be used as a seating surface. Packing glands and/or stuffing boxes are not permitted and there shall be no pistons operating the valve. All necessary repairs shall be possible without removing the valve from the line. If the diaphragm becomes damaged the valve shall close tight. This valve shall be a Model 100-34 (globe pattern or angle pattern) Hytrol Valve as manufactured by Cla-Val. Newport Beach, California.

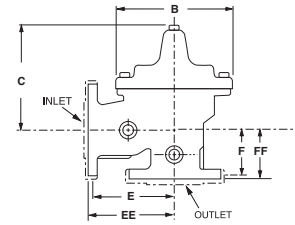

Specify When Ordering

1. Size
2. Model 100-34 Globe or Angle
3. Pressure Class
4. Temperature and fluid to be handled
5. Static and flowing line pressure
6. Operating fluid and pressure (if other than line pressure)
7. Body and trim materials
8. End details

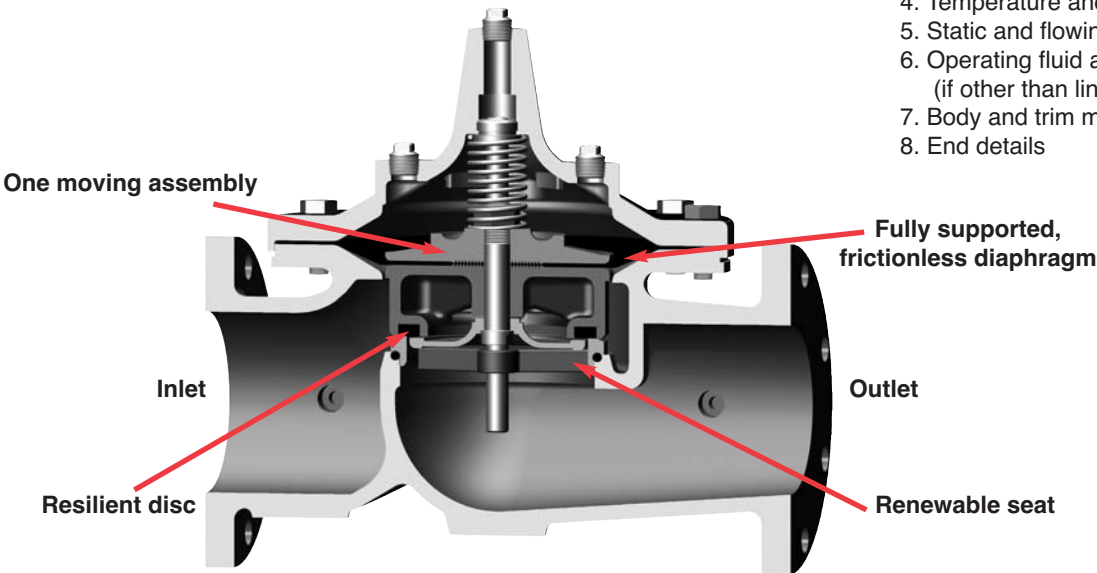

CLA-VAL

CLA-VAL UK Limited
 info@cla-val.co.uk - 01892 514400
 www.cla-val.co.uk

©COPYRIGHT CLA-VAL 2014 Printed in USA
 Specifications subject to change without notice.

Reduce your waste - Sort your rubbish

Represented By: