

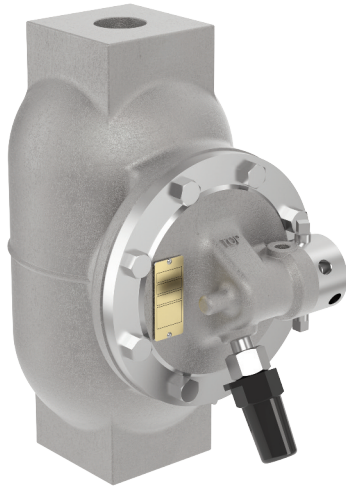

— MODEL — **CFC2T**

Float Control For Closed Tanks with X75A Float Tester Assembly



- Accurate Liquid Level Control
- Fully Hydraulic Operation
- Simple Design, Easy Maintenance
- No Lubrication Necessary
- No Gears, No Mechanical Linkage Between Valve and Control

The Cla-Val Model CFC2 Float Control is a float-actuated, multi-port pilot control which provides non-modulating, two-position, on-off operation. It is used primarily to operate remotely located Cla-Val Valves requiring three-way or four-way pilot valve operation. Designed for use in closed tanks, this control operates on a minimum level change of approximately one inch. Maximum level change of five and one-half inches is needed for full capacity.

Note: We recommend protecting the control tubing and valve from freezing temperatures.

Specifications

Control Piping Connections 1/8" NPT

Reservoir Connections 1" NPT

Pressure Rating 0-150 psi

Temperature Rating Water: to 180°F.

Materials In contact with operating fluid:
Brass, Stainless Steel, Monel, with Buna-N® Seals
Float chamber:
Cast Iron
Pilot valve housing:
Bronze
Materials in contact with operating fluid:
Brass, Stainless Steel, Monel with Buna-N® Seals

Level Differential Approximately 1" minimum required to change pilot valve operation. 5 5/8" required to develop full capacity.

Operating Fluids Clean liquids or gases compatible with specified materials.

Shipping Weight 12 lbs.

Float ball:
Stainless Steel
Float arm:
Brass
Other material available:
Cast steel or aluminum chamber and pilot valve housing. All stainless steel

Dimensions (In Inches)

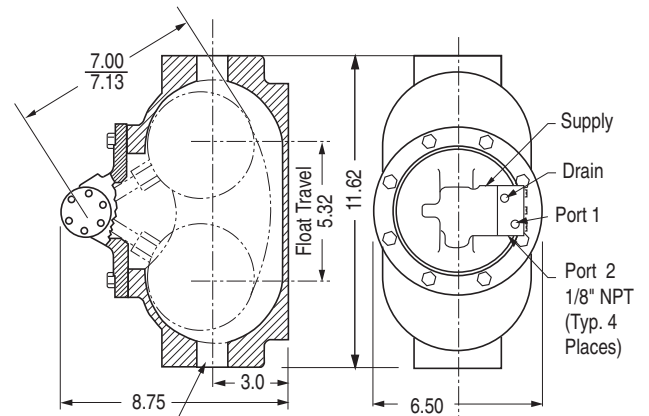

Reservoir Connection
1" NPT (Typ. Both Ends 2 Places)

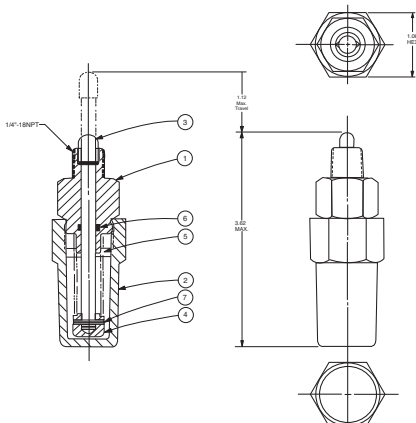

ITEM NO	DESCRIPTION	QTY
1	PLUG GUIDE	1
2	CAP	1
3	STEM RISER	1
4	BUTTON	1
5	SPRING	1
6	O-RING	1
7	ROLLPIN	1

**X75A Float Tester
Assembly**

Typical High Level Shutoff Hook-up For Aviation Fueling Valve Applications

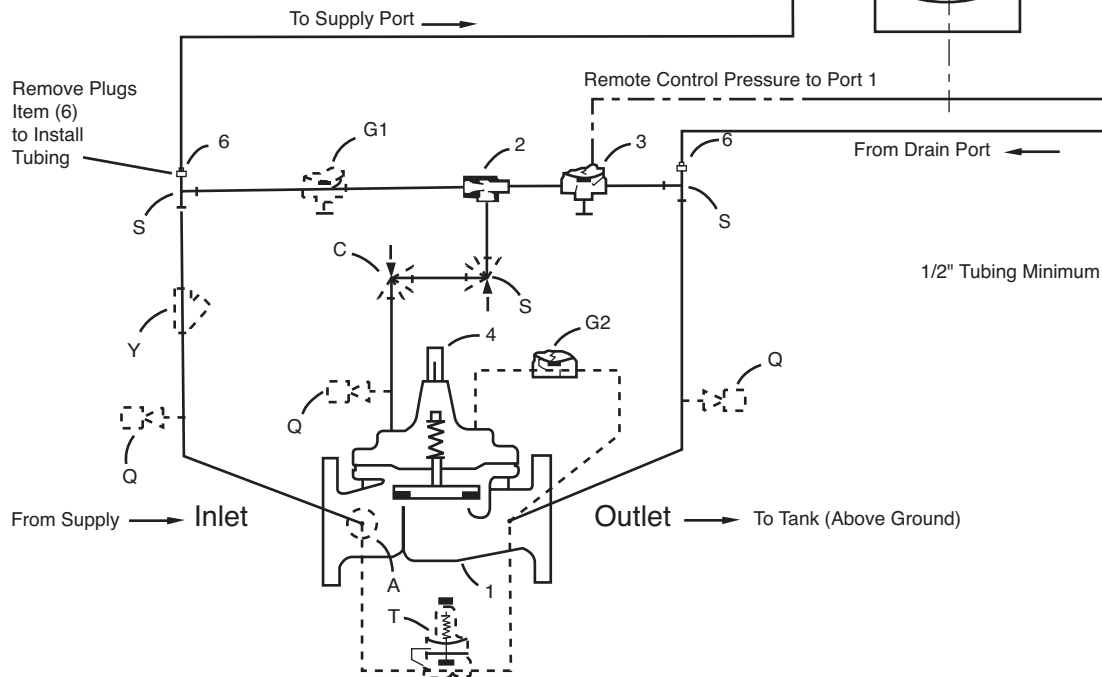
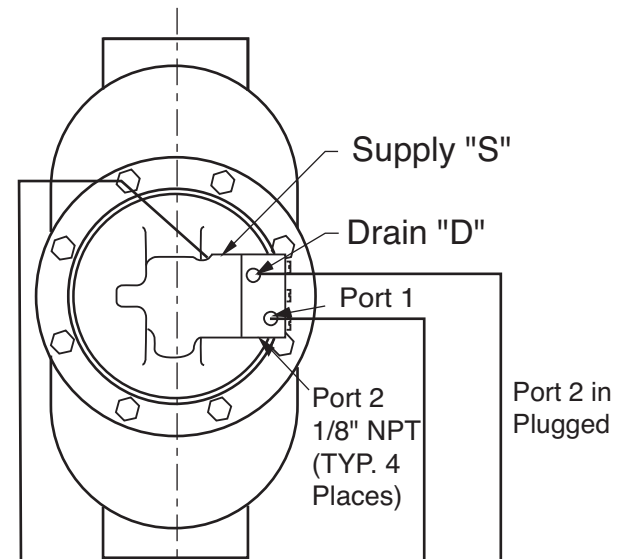
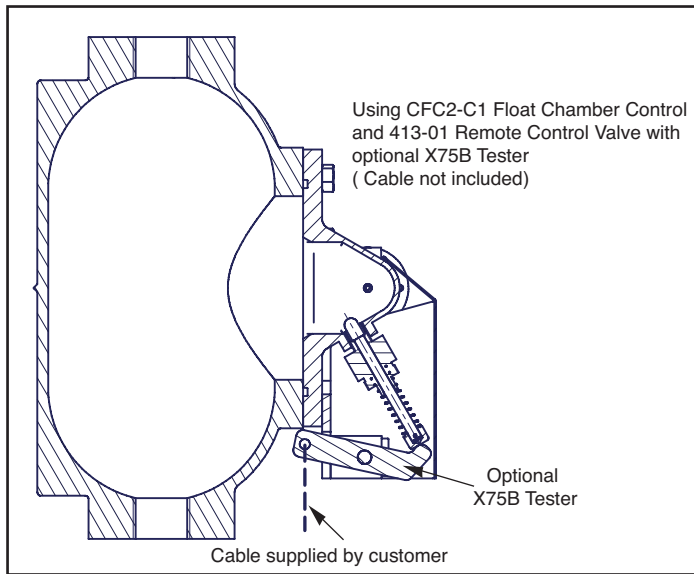

CLA-VAL UK Limited
 info@cla-val.co.uk - 01892 514400
 www.cla-val.co.uk

Reduce your waste - Sort your rubbish

CLA-VAL CANADA
 4687 Christie Drive
 Beamsville, Ontario
 Canada L0R 1B4
 Phone: 905-563-4963
 E-mail: sales@cla-val.ca

CLA-VAL EUROPE
 Chemin des Mésanges 1
 CH-1032 Romanel/
 Lausanne, Switzerland
 Phone: 41-21-643-15-55
 E-mail: cla-val@cla-val.ch

CLA-VAL UK
 Dainton House, Goods Station Road
 Tunbridge Wells
 Kent TN11 2 DH England
 Phone: 44-1892-514-400
 E-mail: info@cla-val.co.uk

CLA-VAL FRANCE
 Porte du Grand Lyon 1
 ZAC du Champ du Pérignon
 France - 01700 Neyron
 Phone: 33-4-72-25-92-93
 E-mail: cla-val@cla-val.fr

CLA-VAL PACIFIC
 45 Kennaway Road
 Woolston, Christchurch, 8023
 New Zealand
 Phone: 64-39644860
 www.cla-valpacific.com
 E-mail: info@cla-valpacific.com